

# Future improvements on performance of an EU landfill directive driven municipal solid waste management for a city in England

Dan Wang, Yu-Ting Tang, Gavin Long, David Higgitt, Jun He, Darren Robinson



**University of  
Nottingham**

UK | CHINA | MALAYSIA

University of Nottingham Ningbo China, 199 Taikang East Road, Ningbo, 315100, Zhejiang, China.

First published 2019

This work is made available under the terms of the Creative Commons Attribution 4.0 International License:

<http://creativecommons.org/licenses/by/4.0>

The work is licenced to the University of Nottingham Ningbo China under the Global University Publication Licence:

<https://www.nottingham.edu.cn/en/library/documents/research-support/global-university-publications-licence.pdf>



**University of  
Nottingham**

UK | CHINA | MALAYSIA

**Future Improvements on Performance of an EU Landfill Directive Driven  
Municipal Solid Waste Management for a City in England**

Dan Wang <sup>a</sup>, Yu-Ting Tang <sup>b\*</sup>, Gavin Long <sup>c</sup>, David Higgitt <sup>e</sup>, Jun He <sup>a\*</sup>, Darren Robinson <sup>d</sup>

<sup>a</sup> International Doctoral Innovation Centre, Department of Chemical and Environmental Engineering, University of Nottingham Ningbo China, Ningbo, Zhejiang, PR China

<sup>b</sup> School of Geographical Sciences, University of Nottingham Ningbo China, Ningbo, Zhejiang, PR China

<sup>c</sup> Laboratory for Urban Complexity and Sustainability, University of Nottingham, Nottingham, United Kingdom

<sup>d</sup> School of Architecture, University of Sheffield, Sheffield, United Kingdom

<sup>e</sup> Lancaster University College at Beijing Jiaotong University, Weihai, Shandong, China

\* Correspondence to:

Dr Jun He, email: [jun.he@nottingham.edu.cn](mailto:jun.he@nottingham.edu.cn);

Dr Yu-Ting Tang, email: [yu-ting.tang@nottingham.edu.cn](mailto:yu-ting.tang@nottingham.edu.cn);

## **Abstract**

Sustainable municipal solid waste (MSW) management is regarded as one of the key elements for achieving urban sustainability via mitigating global climate change, recycling resources and recovering energy. Landfill is considered as the least preferable disposal method and the EU Landfill Directive (ELD) announced in 1999 requires member countries to reduce the volume of landfilled biodegradable materials. The enforcement of ELD initiated the evolution of MSW management system UK. This study depicted and assessed the transition and performance of MSW management after the millennium in Nottingham via materials flow analysis (MFA), as well as appropriately selected indicators based on the concept of waste management hierarchy and targets set in waste management regulations. We observed improvements in waste reduction, material recycling, energy recovery, and landfill prevention. During the period 2001/02 to 2016/17, annual waste generation reduced from 463 kg/Ca to 361 kg/Ca, the recycling and composting share increased from 4.6% to 44.4%, and the landfill share reduced from 54.7% to 7.3%. These signs of progress are believed to be driven by the ELD and the associated policies and waste management targets established at the national and local levels. An alternative scenario with food waste and textile separation at source and utilizing anaerobic digestion to treat separately collected organic waste is proposed at the end of this paper to fulfil the high targets set by local government and we further suggest that the recycling share may be improved by educating and supporting the public on waste separation at the sources.

*Keywords:* Municipal solid waste management; Policy-driven transition; EU Landfill Directive; Nottingham; Material flow analysis; Separate collection.

## **1. Introduction**

Municipal solid waste (MSW) management systems are complex owing to increasing connectivity amongst policies, regulations, socio-cultural contexts, environmental conditions, economic development and/or available resources (Sharholy et al., 2007). MSW managers are challenged by increased quantity and ever diversified composition of MSW produced by growing populations and consumption resulting from urbanization and industrialization (Shmelev and Powell, 2006, Manaf et al., 2009). The environmental and social consequences resulting from MSW management, especially landfill, are profound (Laurent et al., 2014a). Landfill is commonly regarded as the least preferable MSW treatment because of its high contamination potential including water and soil pollution due to the leachate seepage and greenhouse gases (GHGs) emission resulting from the decomposition of biodegradable waste (El-Fadel et al., 1997, Laurent et al., 2014a). These adverse impacts can be diminished by adopting more sustainable MSW management strategies such as material recycling and energy-from-waste (EfW), i.e. anaerobic digestion (AD), incineration with energy recovery (Laurent et al., 2014b, Brunner and Rechberger, 2015).

To combat the challenges of managing the increasing amount of waste and associated adverse impacts on human health and the environment from landfills, the EU Landfill Directive (EU Directive 99/31/EC) (ELD) was introduced in 1999

(Burnley, 2001). ELD places particular limits on the quantity of biodegradable municipal waste (BMW) sent to landfills. EU Member States were required to bring into force the laws, regulations and administrative provisions to comply with ELD within two years of its entry into force (EC, 1999). Thereafter, the EU Waste Framework Directive (EU Directive 2008/98/EC) established a “waste management hierarchy”, which places the following strategies in descending order of priority: prevention, reuse, recycling, recovery and landfill. The EU directives have been transposed into national legislations in EU member states as part of European waste management strategy development, to encourage separate collection and waste pre-treatment, as well as upgrading disposal methods (Vehlow et al., 2007, Lasaridi, 2009, Costa et al., 2010, Stanic-Maruna and Fellner, 2012, Brennan et al., 2016). In England, MSW management strategies were successively introduced for diverting waste from landfills by introducing recycling and recovery practices (SE, 2000, Burnley, 2001, Fisher, 2006). Many researches have been conducted to identify the challenges of meeting the targets set in the EU directives (Price, 2001, Lasaridi, 2009, Stanic-Maruna and Fellner, 2012), to analyse the influences of the EU directives on waste management legislations and practices (Taşeli, 2007, Závodská et al., 2014, Stanic-Maruna and Fellner, 2012, Scharff, 2014), and to evaluate the environmental impacts of potential waste management scenarios or technologies (Pires et al., 2007, Emery et al., 2007, Ionescu et al., 2013, Závodská et al., 2014). However, less attention has been paid on the process how

EU directives have driven the evolution of waste management and the extent to which the performance of waste management has been improved under the guidance of the EU directives.

The evolution of waste management driven by the EU directives, and the performance of a waste management system can be measured by tracking the change of waste management legislations and strategies responding to the EU directives and comparing the historical and current status to the targets (Zaccariello et al., 2015). Such comparisons can be made by using the methodologies of materials flow analysis (MFA), life-cycle assessment and risk analysis with a series of representative indicators (Zaccariello et al., 2015, Parkes et al., 2015, Coelho and Lange, 2018, Masebinu et al., 2017). MFA analyses the flux of materials used and transformed as the flow goes through a defined space, a single process or a combination of processes within a certain period (Belevi, 2002, Rotter et al., 2004). Taking the hidden flows and sinks into account, it provides an approach to thoroughly understand the elements and processes of a waste management system, to identify opportunities for improving the performance of MSW management (Owens et al., 2011, Zaccariello et al., 2015, dos Muchangos et al., 2016), and to select the most promising strategy to do so (Dahlén et al., 2009, dos Muchangos et al., 2016, Zaccariello et al., 2015).

Indicators can be useful in measuring and tracking the performance of waste management practices on a regular basis in a coherent and articulate manner (Wilson et al., 2012, Greene and Tonjes, 2014), and evaluating waste streams as well as environmental impacts and waste treatment efficiency (Rotter et al., 2004, Desmond, 2006, Wen et al., 2009, Greene and Tonjes, 2014, Teixeira et al., 2014, Zaccariello et al., 2015, Bertanza et al., 2018). Waste management hierarchy is the basis for building sustainable MSW management and correspondingly influence the choice of suitable indicators to evaluate the performance of MSW management system. For example, recycling rate, recovery rate and landfill rate are frequently used as indicators to measure the performance of a waste management system (Zaccariello et al., 2015, Pomberger et al., 2017, Haupt, et al, 2017).

In this vein, we have analysed and compared the MSW generation and management practices in Nottingham since the enforcement of ELD (from 2001/02 to 2016/17) based on statistics of waste generation and flows. We aim to thoroughly evaluate the effectiveness of waste management policies and regulations on improving the performance of waste management practices, and to identify the positive and negative changes in relation to the revision of the management strategies/policies, then to propose an alternative scenario having a better performance on managing MSW which could meet the targets set in national and local regulations for Nottingham, as well as to provide experiences and references for the cities alike.



## **2. National and local waste management strategies responding to ELD**

The implementation of the ELD has been widely enforced in EU Member States for producing, collecting and disposing of waste (Pan and Voulvoulis, 2007, Taşeli, 2007, Lasaridi, 2009, Apostol and Mihai, 2011, Stanic-Maruna and Fellner, 2012). Three national level targets were set up to reduce the amount of BMW disposed to landfill for England (Appendix A) (EC, 1999). Later, the Waste Framework Directive upgraded and extended ELD from limiting landfilled waste to establishing sustainable waste management; accordingly, promoting recycling target and separate collection requirement (Appendix A) (EC, 2008). The Packaging and Packaging Waste Directive has been amended three times for the better management of packaging waste by strengthening the waste prevention through product design, charging on carrier plastic bags and promoting recycling and recovery of packaging waste (EC, 2004, 2005, 2015).

### *2.1. Waste strategies in England in response to EU policy*

Three main waste management strategies, highlighted in Fig. 1, were successively published in England for implementing the requirements of the EU directives, including detailed management targets (Appendix A). Waste management programs and regulations were also launched to facilitate achievement of the national targets. For example, the Waste and Resource Action Programme (WRAP) was set up in 2000 to promote sustainable waste management, by

launching a series of campaigns and measures to educate and support public recycling and reusing waste, as well as changing consumption behaviour. WRAP also cooperates with various communities, industries and government to make production and consumption more sustainable (WRAP, 2018a; WRAP, 2018b). Landfill Allowance Trading Scheme (LATS) was introduced in 2005 to progressively reduce the amount of BMW that could be landfilled (Fisher, 2006). As a result, the landfilled BMW was reduced by 7% annually during 2005/06–2011/12, though LATS was suspended after 2012/13 because of its coexistence with the Landfill Tax, which applies similar enforcement (Calaf-Forn et al., 2014).

In addition to these strategies, a variety of waste treatments were gradually introduced to improve the efficiency and performance of waste management (Ryu et al., 2007, DEFRA, 2013). These included mechanical and biological treatment, production of refuse derived fuel (RDF), compost, AD, gasification, and pyrolysis. In this way, the targets and strategies have facilitated the practices of waste management based on the waste management hierarchy moving from the least favourable option to preferable options for waste disposal (Uyarra and Gee, 2013). Since the implementation of the national waste management strategies, the national recycling and composting rates of household waste have been steadily improved, while landfill rate has been gradually reduced (Appendix A).

The national regulations also drove the changes in waste collection and classification. The Household Waste Recycling Act 2003 required local authorities to collect at least two types of recyclables together or individually separated from the rest of the household waste by the end of 2010; this separate collection of recyclables, through the kerbside Collection Scheme, was progressively provided to every household (DEFRA, 2005). This resulted in an improvement in waste recycling and a reduction in landfill volume, especially the landfilled BMW fraction by separating green garden waste. As results, the recycling and composting share of household waste in England increased from around 10% in 2001 to 44% in 2015 (DEFRA, 2016), the landfill share of MSW reduced from 84% in 1996/7 to 44% in 2015 (Ryu et al., 2007, EA, 2016), and the landfilled BMW in 2016 reduced to 21% of that in 1995 (DEFRA, 2018a).

## *2.2. Local strategies in response to EU and England policies*

Nottingham is one of the core cities in England. Around two-thirds of Nottinghamshire's population lives in, or close to, Nottingham. In 2016, Nottingham had a population of 325,282 comprised of 135,000 households occupying 7,538 hectares of land. Since the launch of ELD, a series of actions have been undertaken in Nottingham to prevent unnecessary waste generation and to divert waste from landfill to material recycling and energy recovery in response to the EU and national policies (Fig. 1) (NCC, 2006, NCC, 2009, NCC, 2010). An

Integrated Waste Management Strategy based on the waste management hierarchy was proposed by Nottingham City Council and Nottinghamshire County Council, upon the launch of the Waste Strategy for England 2000 (NCCE, 2002). Waste prevention was especially emphasised and reduction targets were set in local waste management strategies (Appendix A) (NCC, 2010). Initially, sustainable MSW management strategies were proposed by local government and a variety of public related engagements and education were carried out to promote waste prevention (Fig. 1) (NCC, 2000). However, the projects were mostly voluntary; there was no legal basis for enforcing the change of consumption behaviours. It was worth noting that the household waste production in Nottingham was 414 kg per capita per year in 2008/09, already much lower than that in other core cities in England (NCC, 2010). It is possible that in the long term these initiatives may have contributed to waste reduction.

In addition to these initiatives and waste reduction programmes, waste management schemes introduced to supplement the waste management hierarchy includes kerbside collection, EfW and production of RDF. Kerbside collection was introduced in 2002, then the number of households served by it and the types of recyclables to be collected have expanded annually (NCC, 2006, NCC, 2009). For the waste that may not be recycled, alternative solutions for waste treatment other than landfilling have been developed. Eastcroft EfW built in the early 1970s, was retrofitted and upgraded in 1998 to generate energy from waste in the form of

combined heat and power. It is able to incinerate 170,000 tonnes waste per year (FCC Environment, 2015). The technologies of producing RDF were introduced in 2009 to improve the energy recovery efficiency. These investments in waste treatment infrastructure did not only reduce the amount of landfilled waste to fulfil the national and EU targets, but also provide new resources for energy generation.

### **3. Materials and methods**

#### *3.1. The definition of MSW*

There are various definitions of MSW (Buenrostro and Bocco, 2003, Masebinu et al., 2017, Tang and Huang, 2017). MSW defined among EU members of states or their municipalities may not be consistent. Indeed, the ambiguity and inconsistency of the definitions may affect the way the EU directive is implemented and the management progress can be compared among countries or cities (Buenrostro et al., 2001, Buenrostro and Bocco, 2003, Masebinu et al., 2017).

MSW is generally defined as the solid waste collected by (or on behalf of) a local authority from all the households and part of the industrial, commercials and institutional entities, so long as the waste produced by these sources is of a similar nature and composition as household waste (Burnley, 2001, Shekdar, 2009, Masebinu et al., 2017). In Nottingham, MSW is defined as all the solid wastes including household waste and any other wastes collected by a Waste Collection Authority, or its agents, or managed by the Waste Disposal Authority (NCC, 2010).

Separately collected hazardous waste and healthcare waste are normally excluded from the scope of MSW in all definitions. In practical, the collection of industrial and commercial waste is different and separate from that of household waste in Nottingham. Therefore, in this study, we take conceptualised MSW as household waste (i.e. excluding hazardous, healthcare, industrial and commercial wastes), for which we have been able to obtain relatively complete statistics in Nottingham and assessed the MSW management performance using the household waste centred targets set in the EU Directives and national plans.

### *3.2. Data Collection*

Quarterly data on MSW waste collection, recycling and disposal from April 2006 to March 2017 (earliest and latest data available at the time for writing) in Nottingham has been recorded in the WasteDataFlow Database ([www.wastedataflow.org](http://www.wastedataflow.org)). To fill the data gap between the year when ELD started and 2006, around fifty related documents recorded during the period 2000-2016, including meeting records and governments plans, were obtained from local government websites. These documents were critically reviewed by comparing the data from different sources to confirm the reliability of these documents, for further understanding the transition of local MSW management after ELD came into force. National statistical data was also collected to complement and/or verify the analysis

in this study. Detailed data and data sources used for MFA are depicted in Appendix A.

MSW Composition in England in 2006 (Table 1) published by Department for Environment, Food & Rural Affairs (2009) and local MSW Composition in 2013 (Table 1) recorded in an unpublished government report (NCC, 2013) were adopted for our MFA in year 2006/07 and 2016/17 because the data of MSW composition in these two years for Nottingham was unavailable.,

### *3.3. Boundary for Waste Inventory in MFA*

The spatial boundary of the MSW management system was the administrative boundary of Nottingham City Council. The temporal boundary was the statistical year from April to March of the next year; for example, April 2016 – March 2017. The processes analysed included in the MSW management system comprise generation, collection, treatment and disposal. Waste treatment facilities were identified from WasteDataFlow ([www.wastedataflow.org](http://www.wastedataflow.org)). Reprocessing and utilization of secondary materials were not included in the assessment.

### *3.4. Historical states and alternative scenario of MSW management*

Three historical situations (S1 – S3) and an alternative scenario (S4) of MSW management were assessed and compared to assess the transition of MSW

management and to facilitate the future improvement for meeting the targets set in waste management regulations.

*S1* The historical state of MSW management in 2001/02. This was the year when EU Landfill Directive put into enforcement in Nottingham and the earliest year recorded the amount of waste generated and disposed. In 2001/02, weekly house-to-house collection without separation was provided by the local authority (Parfitt et al., 2001). Landfill was the main waste disposal method, followed by incineration with energy recovery (NCC, 2005). Recyclable materials were collected at Civic Amenity (CA) site (also known as Household Waste Recycling Centre) and bring sites (also known as Mini Recycling Centres) (NCC, 2005).

*S2* The historical state of MSW management in 2006/07. This was the year before the enforcement of the Waste Framework Directive and the earliest year documented waste flows. In S2, waste management initiatives, such as kerbside collection, bespoke bulky waste collection and material recovery facility (MRF), had been introduced to separate recyclable materials at source and prepare materials for recycling, but not fully implemented. Incineration with energy recovery became the dominate method for the disposal of MSW, followed by landfilling. Metal from bottom ash was recycled. Garden waste was separately collected and treated via open windrow composting.



S3 The historical state of MSW management in 2016/17. This was the year with the latest data at the time for analysis. Hundred percent of households were served by kerbside collection. Only residual waste from MRF and fly ash from incinerator were landfilled. Production of RDF had been introduced. Bottom ash was recycled for aggregates.

S4 An alternative scenario based on the same quantity and quality of waste in S3 with improved source segregation and alternative waste treatment. Food waste is separately collected. Textile is added into the categories of waste collected through kerbside collection. AD replaces open windrow composting for treating food and garden waste. Biogas from AD is utilized for power and heat generation. Residual waste used to be incinerated is pre-treated in residual MRF for material recycling and RDF production before incineration.

### *3.5. Selection of performance indicators*

As listed in Table 2, five indicators based on the waste management hierarchy and targets set in waste management regulations were selected to evaluate the performance of MSW management in Nottingham. Waste prevention ranks the highest on the waste management hierarchy and is regarded as the most desirable option to divert waste from landfill (Gertsakis and Lewis, 2003); besides, reduction targets are set in local waste management plans. The effectiveness of waste prevention policies could be measured by calculating the waste generation per

capita (GPC) (Desmond, 2006). Recycling is at the second top on the waste management hierarchy and recycling targets are often defined in waste regulations and management strategies (EC, 1999, DEFRA, 2007). Recycling rate (RCR) reflects the collective efficiency during sorting and selection steps to prepare the recyclable materials for reprocessing (Zaccariello et al., 2015). Source-separated collection, measured by separate delivery rate (SDR), is a critical component of an effective MSW management system (Zhuang et al., 2008) and identified as the effective mean in landfilled waste minimization and resource utilization; it may increase the quantity and quality of well sorted waste (Rigamonti et al., 2009, Zhuang et al., 2008), so as to improve RCR (Ghani et al., 2013, Tai et al., 2011). Besides, recovering energy from waste which can be measured by recovery rate (RECR), is another important function of MSW management (Othman et al., 2013). The last option for waste management is landfill, which can be measured by landfill rate (LCR).

Generally, smaller values on GPC and LCR or higher values on RCR, SDR and RECR indicate a better performance of an MSW management system. To make the research results comparable to the targets which are usually set as the recycling and composting rates in waste management regulations, RCR has been adjusted to combine the share of recycled and composted waste. Waste sent to residual MRF is separately collected street waste, bulky waste and residual waste from CA site, but they are not included in the calculation of SDR because the waste from these

sources are mixed waste with heterogeneous materials and the recycling potential of them is low.

#### **4. Results and Discussions**

Fig. 2 and 3 illustrate the material flows in S2 and S3. The major improvements in S3 identified are the increase of SDR and the reduction of waste sent to landfill. Other notable improvements include the reduction of waste generation (from 129,814 tonnes to 115,170 tonnes) and the amount of incinerated waste (from 73,333 tonnes to 66,287 tonnes). Thus, the reduction of landfilled waste is achieved by measures in all levels of waste management hierarchy. The results of MFA are presented in detail in the following sections to demonstrate in what way the values of those indicators are changed under the driving of waste management regulations.

##### *4.1. Waste prevention*

GPC increased slightly from 463 kg in 2001/02 to 466 kg in 2006/07, then decreased to 361 kg in 2016/17 (Fig. 4), which was significantly lower than the national level (412 kg) (DEFRA, 2018b). This contributed to the total MSW reduction from 123,615 tonnes to 115,170 tonnes although population increased by 19.4% during the study period (Table 3). Since 2011/12, GPC was lower than the target (390 kg) to be met by local government by 2025 (Fig. 4).

The improvement of public awareness on waste prevention played an important role in waste reduction. Both national and local waste prevention programmes, such as WRAP, and public education initiatives raised public awareness to reuse products before their disposal. As a result, the waste generation in the city significantly reduced under most waste categories and as a whole (Fig 4 and Table 3). The recent policy to charge for single-use carrier bags, which was introduced in October 2015, reduced the generation of plastic waste as can be seen in Table 3. By contrast, a notable increase in textile waste was observed during the study period, which might be attributed to the development of fast fashion industry in recent years (Perry, 2018, Wicher, 2016, Morgan and Birtwistle, 2009).

Social and economic developments are other possible factors affecting waste generation and reduction in a number of ways. GPC is generally regarded as positively correlated with the income, population and population density (Dahlén, et al., 2009, Das, et al., 2019). The average earnings without taking inflation into account increased during the study period; however, the 'real' earnings adjusted for inflation have declined in every year since 2009 and are at levels last seen in the early 2000s (NCC, 2015). The decrease of 'real' earnings seems potentially reduced the GPC, but positive correlation between the number and percentage of workless households and the GPC was observed (Fig. 4 and Appendix A). Besides, the GPC declined steadily during the study period and was remarkably lower in 2016/17 than that in 2001/02 and 2006/07. The GPC is not always correlated with income

because decoupling of income and waste generation might occur (Namlis and Komilis, 2019). Some researchers also reported that the correlation between income and GPC sometimes is weak in developed countries (Dahlén, et al., 2009, Passarini, et al., 2011, Namlis and Komilis, 2019), even in developing countries (Miezah, et al., 2015). The population and population density increased from 278,700 and 37 persons/ha in 2006 to 318,901 and 42 persons/ha in 2014, but they had not resulted in the increase on waste generation. The average family size increased from 2.2 persons/household to 2.4 persons/household from 2006 to 2016. It is believed that bigger family size might lead to smaller GPC (Miezah, et al., 2015). The social and economic factors influence waste generation from different directions. Overall, the GPC showed a decreasing trend during the study period.

#### *4.2. Separate delivery*

SDR in Nottingham increased from 22.2% in 2006/07 to 33.3% in 2016/17 due to the introduction and expansion of kerbside collection, and resulted in the improved recycling share, and a high interception of garden waste (90.0%) (Fig. 2 and 3). Kerbside collection has been demonstrated to be the most efficient and sustainable separate collection scheme (Tucker et al., 1998, Larsen et al., 2010). It was introduced to Nottingham in 2002 for separating paper at source. Thereafter, the categories of material collected in the scheme and spatial extent of the scheme were increased year by year. The expansion was so significant that in 2008, the

local authority started to offer three types of wheeled bin for waste containment to households for free for separating recyclable materials and garden waste at sources (Fig. 1). From 2006/07 to 2016/17, the percentage of households served by kerbside collection increased from 4.7% to 100%, and the proportion of households received separate garden waste collection increased from 32.7% to 74.4%. Other types of containment, such as orange survival bags, communal bins, refuse bins and plastic sacks were offered in areas not covered by kerbside collection but the number of bring sites where recyclable materials used to be collected reduced from 88 to 17. It is also noted that the quantity of street waste and other waste received by residual MRF site all reduced. The improvement of source-separated collection in the past decades was directly related to the implementation of kerbside collection in Nottingham.

The SDR of textiles was very low and reduced from 5.2% to 1.3% during 2006/07 – 2016/17. Textile is not included in the waste categories collected by kerbside collection. Recyclable textile was usually collected at bring sites and CA sites. The reduction of the number of bring sites may have reduced accessibility to facilities for textile recycling without replacement, as the average distance between households and bring sites increased. Further, usually the second-hand textile products that are reusable with minimal fixation can be accepted in charity shops, rather than being brought to the recycle centres; clothes that cannot be worn any longer may be put in a residual bin and sent to the incineration plant intuitively by

the owners, while in fact, these disposed unwearable cloth could have been used as wiping and polishing cloth, or reprocessed into textile products such as nonwovens and mats (Wang, 2010). Recycled polymers could be used as matrices in glass fibre reinforced composites or to make producers in a moulding process (Wang, 2010). Recycling textile can contribute to reduce the environmental burden compared to using virgin materials (Woolridge et al., 2006). However, for the time being, the increased textile waste has been used more for the energy recovery (RECR 96.90% for S3, Table 3).

#### *4.3. Recycling and composting*

RCR in Nottingham has significantly increased from 3.4% in 2001/02 to 17.6% in 2006/07, then to 31.9 % in 2016/17. The values are higher when including the composted waste (Table 3), but another over 5% of waste needs to be recycled or composted to reach the national and local targets of recycling and composting 50% of household waste by 2020. The recycling and composting rate in 2016/17 in Nottingham, taking recycled bottom ash into account, was equal to the national level of 44.9% which excludes the recycled bottom ash (DEFRA, 2017). It is possible to meet the target if separate source collection is further improved. On the other hand, based on the relatively low GPC (section 4.1), we cannot exclude the possibility that public awareness of prevention and reuse before recycling contributed to the declined proportion of recyclable materials in MSW. The positive

effort in prevention is also reflected in the declined amount of glass, paper and cardboard with increased RCRs.

The improvement of public awareness on waste recycling and the improved technologies and techniques on waste collection, sorting and treatment driven by the waste management regulations are the factors contributing to the improvement of RCR. The combination of the kerbside collection and public education on waste recycling led the improvement of waste separation at source, especially for garden waste, thus the improvement of RCR. Recycling materials from residual waste through residual MRF and bottom ash utilization further improved the RCR. However, the improved RCR often sacrifices the quality of secondary materials due to the accumulation of hazardous substances (Kral et al., 2013), and the accumulation of hazardous substances is more likely to happen when materials are recycled from residual waste or bottom ash. Apart from improving the public awareness on waste recycling and classification to reduce the contamination of recyclables, more attention should also be paid on improving the quality of secondary products rather than meeting the quantitative targets.

RCRs of all waste categories, except textile, were maintained if not improved (based on the RCR values in S2 and S3, Table 3), although still a large fraction of metal and glass were addressed to landfill or recycled as aggregates with bottom ash. To further reduce the landfill volume, plans and actions relating to recycling



textile, glass and metal may be needed in future waste management. Unrecyclable plastic materials such as plastic film, packaging waste and single-use carrier bags account for a big proportion in plastic waste, making the RCR of plastics low (3.8% in S2 and increased to 17.6% in S3). Most of them were treated for energy recovery in both historical states of MSW management. Since plastic waste normally has a high energy content, recovering energy from it is deemed to be an appropriate way of disposing it.

Garden waste accounted for around 15% of MSW in Nottingham. It shares the highest SDR among all waste categories in both S2 and S3. Most garden waste was separately collected at source and sent to farm for fertilisation after being composted. The adoption of composting did reduce the quantity of BMW sent to landfill, but the GHG emission factor of composting is four to five times higher than AD (Fong et al., 2015). Capturing methane from composters or adopting advanced technology to treat garden waste is recommended for reducing the global impact of waste management.

Processing efficiency of separately collected mixed recyclables in MRF reduced from 99.6% in 2006/07 to 81.8% in 2016/17 as the kerbside collection expanded. This most likely is the results of the misclassification at sources, which lead to a high contamination of 14.2% in comingled recyclables. This misclassification might be due to the comparatively low level of outreach or education of households

that were new to the extended kerbside collection scheme. This, in combination with the introduction of additional types of recyclable materials and collection bins, might have confused citizens regarding the ways of classifying and recycling the materials. Thus, an increased portion of unrecyclable materials was mixed with the comingled recyclable collections (BBC, 2017), and around 17% of the materials placed into the residual waste bin were actually recyclable (Appendix A). Educational campaigns combined with economic incentives or punishment to improve waste classification are recommended, to improve the quality of recyclable wastes and thus RCR. On the other hand, in S3, the increased misclassified unrecyclable wastes were sent for producing RDF as a means for energy recovery, instead of being sent to landfill. The development of new technology somewhat made up for the lack of sufficient outreach in this way.

#### *4.4. Energy from waste*

The implementation of EfW incineration and RDF leads a high RECR in Nottingham, 56.5% and 61.9% in both historical situations (Table 3). Residual waste was incinerated in Eastcroft EfW for recovery energy. This has contributed remarkably to reducing the volume of waste sent to landfill and played an important role in improving the performance of the MSW management system in Nottingham. The facility produces nearly 20 MW of thermal energy displacing non-renewable methods for generating electricity and serving around 4,600 homes for heating

(FCC Enviroment, 2015). This contributed to the 3% of the energy consumed in Nottingham in 2006, making it the most energy self-sufficient city in the UK at that time (NEP, 2010). The production of RDF is considered a good way to enhance energy recovery. The proportion of waste separated to produce RDF was increased to 4% in 2016/17.

However, it is undeniable that over half of MSW in Nottingham city was directly incinerated without sorting in 2016/17. Food waste made the greatest proportion of the incinerated residual waste (33.4%) for energy recovery. However, food waste is not suitable for incineration because its high moisture content reduces the calorific value of the waste mixture (Zhang et al., 2010, Bai et al., 2012) and increases the chances of incomplete combustion that produces pollutants such as dioxins and carbon monoxide (McKay, 2002, Tsai and Chou, 2006). Food waste may be better used for making fertilizers after composted, which also produces biogas for energy production (World Energy Council, 2016). Therefore, more effort should be made to separate food waste from residual waste to improve the energy recovery efficiency. By doing so, the food waste is also dealt with using a more favourable (composting or AD) methods based the waste management hierarchy.

#### *4.5. Landfill*

The improvement of recycling and recovery, also prevention, potentially lead to a remarkable reduction of LCR in Nottingham from 54.7% in 2001/02 to

35.3% in 2006/07 and further to as low as 7.3% in 2016/17 (Table 3). In the S3, only the residual waste from residual MRF that cannot be recycled or processed to RDF was landfilled. It is believed that with continued improvement of separated source collection to prevent cross contamination, the LCR can be further reduced to approach the zero landfill target set by the Nottingham Waste Strategy 2010-2030.

#### *4.6. MAF and evaluation of the alternative scenario (S4)*

90% of food waste and reusable textiles are assumed to be separated at source considering the SDR of some waste streams, for instance garden waste, could reach 90%. By taking these actions, the SDR of the MSW management system can be improved to 51.4% (Fig. 5). The composting of garden waste is replaced by controlled AD to produce biogas in addition to fertilizer. The biogas is assumed to be produced with a yield of 20% by weight, of which, 63% is methane (Zaccariello et al., 2015, Turner et al., 2016). The collection of biogas for energy generation may reduce the GHG like methane being directly released into the atmosphere as it would be during the composting process. Residual waste is admitted to MRF first to recycle materials as much as possible. In this process, 80% of recyclable materials in residual waste is assumed to be recycled by considering that the processing efficiency of mixed recyclables in MRF is over 80%. After separating these recyclable materials, 80% of unrecyclable but combustible materials with a

high calorific value, namely plastics, textiles, paper and card, and 20% of combustible materials with a lower calorific value, namely garden waste, food waste and combustible miscellaneous are processed to produce RDF. Then the remaining combustible residual waste is incinerated for volume reduction and energy recovery. Non-combustible waste is sent to landfill. Bottom ash from the incinerator is recycled for aggregates or road construction. In this way, the total recycling and composting rate can reach 63.7% and the LCR will be reduced to as low as 3.6% (Table 3). In S4, the RECR is reduced to 44.8%, 13.4% of which is derived from the organic waste treated in AD. As the reduction of RECR indicates only the reduction of the amount of waste treated for energy recovery, the decreased volume may not be viewed as negative because the quality of waste treated in energy recovery process (heating value) is expected to be improved due to the production of RDF and biogas. The good results in terms of the recycling and composting rate obtained by moving from S3 to S4 demonstrate a waste management with better performance can be achieved by improving separating at source as well as bettering sorting process.

#### *4.7. Opportunities and challenges for future improvements*

Waste prevention is the key to decouple the correlation between economic growth and waste generation. Absolute decoupling between waste growth and economic growth has not been demonstrated in Europe so far (Zorpas, et al., 2014),

but the reduction on the number and percentage of workless households did not result in a growth of GPC in Nottingham. Waste prevention actions such as food waste prevention and establishment of the reuse or exchange networks underpin the waste reduction in Nottingham and should be promoted in future MSW management.

Enhancing source separation seem to play an important role in improving the performance of MSW management in Nottingham, and the public participation will be the most important factor influences the MSW management. On the one hand, most citizens in Nottingham have been well educated for waste minimization, separation and recycling, and kerbside collection system have been well established and implemented. Households are actively involved in the separation and collection process. This is facilitating the separate collection of food waste and textile. On the other hand, the incorporation of the separate collection of food waste changes the current waste management habits of households. The willingness of public to change will be a decisive factor determining the success of this strategy. The study conducted by Bernad-Beltrán, et al. (2014) in Spain demonstrated a high willingness to separate food waste if supportive facilities, for instance, bins are provided by local authority. Besides, adding more waste categories in the kerbside collection list causes confusion easily and increases the difficulty and inconvenience of householders to separate waste at source. This might hinder the public engagements in waste management, and potentially increase the

contamination of separated recyclables, hence reduce the efficiency of sorting and processing and the quality of recycled materials. Therefore, public education and facilities supporting source separation should be strengthened.

Economic development provides opportunities, as well as challenges on MSW management. Local authorities in numerous countries seek partnerships with private enterprises to cut the increasing cost and enhancing the efficiency of MSW management (Massoud and EI-Fadel, 2002). By-products from MSW management bring profits to waste management entities, but the limited market for these products and the poor source separation of waste might have constrained the entry of private entities into the waste management sector (Banerjee and Sarkhel, 2019). At the meantime, increased separated streams requires more investment on technologies, facilities and workers to treat or process them. This will increase the financial burden on local government, as well as entities. Therefore, the improved MSW management should be associated with the expansion and management of the market for secondary products from waste management sector and cost reduction measures such as ensuring the low transaction costs through improving the transparency and effectiveness of market signals (Banerjee and Sarkhel, 2019).

To introduce MRF for the pre-treatment of the waste that was sent to incineration could potentially increase the RCR by recovering recyclables from residuals waste. However, the quantity and quality of recycled materials will be reduced because

recyclable materials are contaminated easily by mixed waste. Alternatively, production of RDF might be possible to improve the RECR of the MSW management system.

#### *4.8. Uncertainties and limitations*

National average value of the household waste composition in 2006 and local waste composition in 2013 were acquired to present the waste composition in Nottingham in 2006/07 and 2016/17 respectively due to the data unavailability. It is acknowledged that using this data could introduce uncertainties of the MFA results. The variation on waste composition might change the values of indicators assessing the management on specific waste streams, for instance, paper and plastics, but it does not change the results of the evaluation of the MSW management system as a whole.

The indicators selected in this study well assessed the performance of the MSW management following the rule of the waste management hierarchy and the targets in waste regulation. However, they have limitations to assess the sustainability of MSW management system. An MSW management system with higher RCR is not necessarily more sustainable than the one with lower RCR because the actually recycled secondary material is also related to the efficiency of reprocessing and the replacement of primary materials (Haupt, et al., 2017). Besides, the quality of recycled materials is not guaranteed with the improved RCR. Kral et al., 2013



pointed out that high recycling rates often contradict high product qualities. A comprehensive assessment on the sustainability of an MSW management systems should always be complemented with a life cycle analysis, and more attention should be paid on the quality of secondary products. Even though, the improvement indeed reflects a level of resources utilization efficiency that has positive consequences of environmental conditions. Furthermore, the improvement of waste collection and recycling system that leads to the reduction of landfilled waste is a reflection of the effectiveness of the EU directives on the improvement of the MSW management.

## **5. Conclusions**

Since 2000, Nottingham has implemented a variety of MSW management policies, regulations and infrastructure to fulfil the EU and national targets. The comparison between historical states of MSW management in Nottingham suggests that the policies and regulations implemented to respond to EU Directives have considerably reduced the waste generation and improved the recycling and energy recovery from waste for the city, but the loopholes in treating the textile waste and food waste were identified. ELD only focus on the reduction of the landfilled materials. Fulfilling the target does not mean the waste management system performs very well. The implementation of Waste Framework Directive which established the “waste management hierarchy” improved on the ELD by focussing

on the performance of the whole system. Nottingham City Council may now consider that a more sophisticated strategy goes beyond the objective of fulfilling the target of the ELD. The system can be further improved by better allocating wastes in the upper layers of the waste management hierarchy and in the layers where the wastes may maximise its potential to be converted into resources (energy and materials).

Waste separation at source is the key to improve the efficiency of waste treatment methods. Hence, at all layers of the waste management hierarchy, effective public education and supportive facilities on waste classification are recommended to accompany the expansion of kerbside collection and the future separation of food waste, so as to reduce the misclassification of the recyclable and recoverable materials. Besides, economic instruments should follow up to manage the secondary products from waste management sector. Waste generation could also be further reduced by decoupling the correlation between economic development and waste generation through waste prevention actions.

### **Acknowledgements**

This work was carried out at the International Doctoral Innovation Centre (IDIC), University of Nottingham Ningbo, China. The author acknowledges the financial support from IDIC, Ningbo Education Bureau, Ningbo Science and Technology Bureau, and the University of Nottingham. This work was also partially supported

by Ningbo Municipal Innovation Team Project (2017C510001) and UK Engineering and Physical Sciences Research Council (EP/G037345/1 and EP/L016362/1).

## **Nomenclature**

ELD	EU Landfill Directive (EU Directive 99/31/EC)
MFA	Materials flow analysis
MSW	Municipal solid waste
AD	Anaerobic digestion
GHG	Greenhouse gas
BMW	Biodegradable municipal waste
WRAP	Waste and Resource Action Programme
LATS	Landfill Allowance Trading Scheme
RDF	Refuse derived fuel
EfW	Energy from Waste
WEEE	Waste Electrical and Electronic Equipment
DEFRA	Department for Environment, Food & Rural Affairs
GPC	Waste generation per capita
SDR	Separate delivery rate
RCR	Recycling rate
RECR	Recovery rate
LCR	Landfill rate
NCC	Nottingham City Council

## **Reference**

- Apostol, L., Mihai, F.C., 2011. The process of closing down rural landfills case study: Neamt county. *Present Environment and Sustainable Development*. 5(2), 167-174.
- Bai, L.C., Bu Y.M., Liu, Q.L., Zhang, X.B., 2012. Engineering analysis on China's municipal solid waste incineration. *China Environmental Protection Industry*. 2, 25-29.
- Banerjee, S., & Sarkhel, P., 2019. Municipal solid waste management, household and local government participation: a cross country analysis. *J. Environ. Plann. Man.* 1-26.
- BBC. 2017. Costing the Earth: Where does our waste go? <http://www.bbc.co.uk/programmes/b098j5lk> (accessed 13 March 2018).
- Belevi, H., 2002. Material flow analysis as a strategic planning tool for regional waste water and solid waste management. *Proceedings of the workshop" Globale Zukunft: Kreislaufwirtschaftskonzepte im kommunalen Abwasser- und Fäkalienmanagement."* GTZ/BMZ & ATV-DVWK Workshop during the IFAT, 13-15.
- Bernad-Beltrán, D., Simó, A., Bovea, M.D., 2014. Attitude towards the incorporation of the selective collection of biowaste in a municipal solid waste management system. A case study. *Waste Manage.* 34(12), 2434-2444.
- Bertanza, G., Ziliani, E., Menoni, L., 2018. Techno-economic performance indicators of municipal solid waste collection strategies. *Waste Manage.* 74, 86-97.
- Brennan, R., Healy, M., Morrison, L., Hynes, S., Norton, D., Clifford, E., 2016. Management of landfill leachate: The legacy of European Union Directives. *Waste Manage.* 55, 355-363.
- Brunner, P.H., Rechberger, H., 2015. Waste to energy—key element for sustainable waste management. *Waste Manage.* 37, 3-12.
- Buenrostro, O., Bocco, G., 2003. Solid waste management in municipalities in Mexico: goals and perspectives. *Resour. Conserv. Recy.* 39, 251-263.
- Buenrostro, O., Bocco, G., Cram, S., 2001. Classification of sources of municipal solid wastes in developing countries. *Resour. Conserv. Recy.* 32, 29-41.
- Burnley, S., 2001. The impact of the European landfill directive on waste management in the United Kingdom. *Resour. Conserv. Recy.* 32, 349-358.
- Calaf-Forn, M., Roca, J., Puig-Ventosa, I., 2014. Cap and trade schemes on waste management: A case study of the Landfill Allowance Trading Scheme (LATS) in England. *Waste Manage.* 34, 919-928.
- Coelho, L.M.G., Lange, L.C., 2018. Applying life cycle assessment to support environmentally sustainable waste management strategies in Brazil. *Resour. Conserv. Recy.* 128, 438-450.

- Costa, I., Massard, G., Agarwal, A., 2010. Waste management policies for industrial symbiosis development: case studies in European countries. *J. Clean Prod.* 18, 815-822.
- Dahlén, L., Åberg, H., Lagerkvist, A., Berg, P.E., 2009. Inconsistent pathways of household waste. *Waste Manage.* 29, 1798-1806.
- Das, S., Lee, S.H., Kumar, P., Kim, K. H., Lee, S.S., Bhattacharya, S.S., 2019. Solid waste management: Scope and the challenge of sustainability. *J. Clean. Prod.* 228, 658-678.
- DEFRA, 2005. Guidance for Waste Collection Authorities on the Household Waste Recycling Act 2003. <https://www.whatdotheyknow.com/cy/request/192033/response/469095/attachment/2/hwra%20guidance.pdf> (accessed 10 November 2018)
- DEFRA, 2007. Waste Strategy for England 2007. <https://www.gov.uk/government/publications/waste-strategy-for-england-2007> (accessed 4 September 2018)
- DEFRA, 2013. Waste Management Plan for England. [https://www.gov.uk/government/uploads/system/uploads/attachment\\_data/file/265810/pb14100-waste-management-plan-20131213.pdf](https://www.gov.uk/government/uploads/system/uploads/attachment_data/file/265810/pb14100-waste-management-plan-20131213.pdf) (accessed 19 November 2016).
- DEFRA, 2016. UK Statistics on Waste. [https://www.gov.uk/government/uploads/system/uploads/attachment\\_data/file/547427/UK\\_Statistics\\_on\\_Waste\\_statistical\\_notice\\_25\\_08\\_16\\_update\\_\\_2\\_.pdf](https://www.gov.uk/government/uploads/system/uploads/attachment_data/file/547427/UK_Statistics_on_Waste_statistical_notice_25_08_16_update__2_.pdf) (accessed 18 November 2016).
- DEFRA, 2017. Statistics on Waste Managed by Local Authorities in England in 2016/17. [https://assets.publishing.service.gov.uk/government/uploads/system/uploads/attachment\\_data/file/664594/LACW\\_mgt\\_annual\\_Stats\\_Notice\\_Dec\\_2017.pdf](https://assets.publishing.service.gov.uk/government/uploads/system/uploads/attachment_data/file/664594/LACW_mgt_annual_Stats_Notice_Dec_2017.pdf) (accessed 15 October 2018)
- DEFRA, 2018a. UK Statistics on Waste. <https://www.gov.uk/government/statistics/uk-waste-data> (accessed 18 November 2016).
- DEFRA, 2018b. Digest of Waste and Resource Statistics - 2018 edition. <https://www.gov.uk/government/statistics/digest-of-waste-and-resource-statistics-2018-edition> (accessed 18 November 2016).
- Desmond, M., 2006. Municipal solid waste management in Ireland: assessing for sustainability. *Irish Geography.* 39, 22-33.
- Dos Muchangos, L.S., Tokai, A., Hanashima, A., 2016. Application of material flow analysis to municipal solid waste in Maputo City, Mozambique. *Waste Manag. Res.* 35, 253-266.
- EEA, 2016. Waste. <https://www.eea.europa.eu/soer-2015/europe/waste> (accessed 30 October 2018).

- El-Fadel, M., Findikakis, A.N., Leckie, J.O., 1997. Environmental impacts of solid waste landfilling. *J. Environ. Manage.* 50, 1-25.
- Emery, A., Davies, A., Griffiths, A., Williams, K., 2007. Environmental and economic modelling: A case study of municipal solid waste management scenarios in Wales. *Resour. Conserv. Recy.* 49, 244-263.
- Environment Agency (EA), 2016. Waste Management 2015 in England: Summary. <https://www.gov.uk/government/statistics/waste-management-for-england-2015> (accessed 23 March 2017).
- European Commission (EC), 1999. Council Directive 1999/31/EC on the Landfill of Waste. Official Journal of the European Communities.
- European Commission (EC), 2004. Directive 2004/12/EC of the European Parliament and of the Council: amending Directive 94/62/EC on packaging and packaging waste. Official Journal of the European Communities.
- European Commission (EC), 2005. Directive 2005/20/EC of the European Parliament and of the Council: amending Directive 94/62/EC on packaging and packaging waste. Official Journal of the European Communities.
- European Commission (EC), 2008. Directive 2008/98/EC of the European Parliament and of the Council on waste and repealing certain Directives. Official Journal of the European Communities.
- European Commission (EC), 2015. Directive 2015/720 of the European Parliament and of the Council: amending Directive 94/62/EC as regards reducing the consumption of lightweight plastic carrier bags. Official Journal of the European Communities.
- FCC Environment, 2015. Annual Performance Report for Eastcroft Energy from Waste Facility: Year 2014.
- Fisher, K., 2006. Impact of Energy from Waste and Recycling Policy on UK Greenhouse Gas Emissions. Environment Resource Management for Department of Environment, Food and Rural Affairs. Prieiga per internetą: <http://randd.defra.gov.uk/Document.aspx>.
- Fong, W.K., Sotos, M., Doust, M., Schultz, S., Marques, A., Deng-Beck, C., 2015. Global Protocol for Community-Scale Greenhouse Gas Emission Inventories (GPC). World Resources Institute: New York, NY, USA.
- Gertsakis, J., Lewis, H., 2003. Sustainability and the Waste Management Hierarchy – a Discussion Paper. EcoRecycle: Vectoria.
- Ghani, W.A.W.A.K., Rusli, I.F., Biak, D.R.A., Idris, A., 2013. An application of the theory of planned behaviour to study the influencing factors of participation in source separation of food waste. *Waste Manage.* 33, 1276-1281.
- Greene, K.L., Tonjes, D.J., 2014. Quantitative assessments of municipal waste management systems: Using different indicators to compare and rank programs in New York State. *Waste Manage.* 34, 825-836.

- Haupt, M., Vadenbo, C. and Hellweg, S. 2017. Do we have the right performance indicators for the circular economy?: insight into the Swiss waste management system. *J. Ind. Ecol.* 21(3), 615-627.
- Huang, S.L., Wong, J.H., Chen, T.C., 1998. A framework of indicator system for measuring Taipei's urban sustainability. *Landsc. Urban Plan.* 42, 15-27.
- Ionescu, G., Rada, E.C., Ragazzi, M., Mărculescu, C., Badea, A., Apostol, T., 2013. Integrated municipal solid waste scenario model using advanced pretreatment and waste to energy processes. *Energy Convers. Manag.* 76, 1083-1092.
- Kral, U., Kellner, K., Brunner, P.H., 2013. Sustainable resource use requires “clean cycles” and safe “final sinks”. *Sci. Total Environ.* 461, 819-822.
- Larsen, A.W., Merrild, H., Møller, J., Christensen, T.H., 2010. Waste collection systems for recyclables: an environmental and economic assessment for the municipality of Aarhus (Denmark). *Waste Manage.* 30, 744-754.
- Lasaridi, K., 2009. Implementing the Landfill Directive in Greece: problems, perspectives and lessons to be learned. *Geogr. J.* 175, 261-273.
- Laurent, A., Bakas, I., Clavreul, J., Bernstad, A., Niero, M., Gentil, E., Hauschild, M.Z., Christensen, T.H., 2014a. Review of LCA studies of solid waste management systems—Part I: Lessons learned and perspectives. *Waste Manage.* 34, 573-588.
- Laurent, A., Clavreul, J., Bernstad, A., Bakas, I., Niero, M., Gentil, E., Christensen, T.H., Hauschild, M. Z., 2014b. Review of LCA studies of solid waste management systems—Part II: Methodological guidance for a better practice. *Waste Manage.* 34, 589-606.
- Makarichi, L., Techato, K. A., Jutidamrongphan, W., 2018. Material flow analysis as a support tool for multi-criteria analysis in solid waste management decision-making. *Resour. Conserv. Recy.* 139, 351-365
- Manaf, L.A., Samah, M.A.A., Zukki, N.I.M., 2009. Municipal solid waste management in Malaysia: Practices and challenges. *Waste Manage.* 29, 2902-2906.
- Masebinu, S.O., Akinlabi, E.T., Muzenda, E., Aboyade, A.O., Mbohwa, C., 2017. Evaluating the municipal solid waste management approach of a city using material flow analysis. *International Conference on Industrial Engineering and Operations Management.* April 11-13, 2017. Rabat, Morocco.
- Massoud, M.A., El-Fadel, M., 2002. Public–private partnerships for solid waste management services. *Environ. Manage.* 30(5), 0621-0630.
- Mckay, G., 2002. Dioxin characterisation, formation and minimisation during municipal solid waste (MSW) incineration. *Chem. Eng.J.* 86, 343-368.
- Miezah, K., Obiri-Danso, K., Kádár, Z., Fei-Baffoe, B., Mensah, M.Y. 2015. Municipal solid waste characterization and quantification as a measure towards effective waste management in Ghana. *Waste Manage.* 46, 15-27.

- Morgan, L.R., Birtwistle, G., 2009. An investigation of young fashion consumers' disposal habits. *Int. J. Consum. Stud.* 33, 190-198.
- Moussiopoulos, N., Achillas, C., Vlachokostas, C., Spyridi, D., Nikolaou, K., 2010. Environmental, social and economic information management for the evaluation of sustainability in urban areas: A system of indicators for Thessaloniki, Greece. *Cities*. 27, 377-384. <https://doi.org/10.1016/j.cities.2010.06.001> .
- Namlis, K.G., Komilis, D., 2019. Influence of four socioeconomic indices and the impact of economic crisis on solid waste generation in Europe. *Waste Manage.* 89, 190-200.
- Nottingham Energy Partnership (NEP), 2010. The Nottingham 2020 Sustainable Energy Strategy. [http://www.nottenergy.com/projects/public\\_sector/the\\_nottingham\\_2020\\_sustainable\\_energy\\_strategy/](http://www.nottenergy.com/projects/public_sector/the_nottingham_2020_sustainable_energy_strategy/) (accessed 09 July 2017).
- Nottingham City Council (NCC), 2000. Report of Chair of Executive Resources Board - Nottingham's Local Agenda 21 Plan 'Change Our City, Change Ourselves'.
- Nottingham City Council (NCC), 2005. Best Value Performance Plan 2005-2006.
- Nottingham City Council (NCC), 2006. Improving Kerbside Recycling Arrangements.
- Nottingham City Council (NCC), 2009. Progress Report of Recently Expanded 3 Bin Recycling Scheme.
- Nottingham City Council (NCC), 2010. A Waste-less Nottingham: Waste Strategy 2010-2030.
- Nottingham City Council (NCC), 2013. Nottingham City Waste Kerbside Composition Analysis.
- Nottingham City Council (NCC), 2015. Annual Survey of Hours and Earnings, 2014.
- Nottingham City Council (NCC), 2017. Annual population survey – households by combined economic activity status.
- Nottinghamshire County Council Environment (NCCE), 2002. Nottinghamshire and Nottingham Waste Local Plan.
- Othman, S.N., Noor, Z.Z., Abba, A.H., Yusuf, R.O., Hassan, M.A.A., 2013. Review on life cycle assessment of integrated solid waste management in some Asian countries. *J. Clean Prod.* 41, 251-262.
- Owens, E.L., Zhang, Q., Mihelcic, J.R., 2011. Material flow analysis applied to household solid waste and marine litter on a small island developing state. *J. Environ. Eng.* 137, 937-944.
- Pan, J., Voulvoulis, N., 2007. The role of mechanical and biological treatment in reducing methane emissions from landfill disposal of municipal solid waste in the United Kingdom. *J. Air. Waste Manag. Assoc.* 57, 155-163.



- Parfitt, J.P., Lovett, A.A., Sünnerberg, G., 2001. A classification of local authority waste collection and recycling strategies in England and Wales. *Resour. Conserv. Recy.* 32(3-4), 239-257.
- Parkes, O., Lettieri, P., Bogle, I.D.L., 2015. Life cycle assessment of integrated waste management systems for alternative legacy scenarios of the London Olympic Park. *Waste Manage.* 40, 157-166.
- Passarini, F., Vassura, I., Monti, F., Morselli, L., Villani, B., 2011. Indicators of waste management efficiency related to different territorial conditions. *Waste Manage.* 31, 785–792.
- Perry, P., 2018. Water Pollution, Toxic Chemical Use and Textile Waste: Fast Fashion Comes at Huge Cost to the Environment. <https://www.independent.co.uk/life-style/fashion/environment-costs-fast-fashion-pollution-waste-sustainability-a8139386.html> (accessed 04 September 2018).
- Pires, A., Martinho, M. G., Silveira, A., 2007. Could MBT plants be the solution of fulfill landfill directive targets in Portugal. *Proceedings of International Symposium MBT 2007*. 22-24 May, Cuvillier Verlag. 63-72.
- Price, J.L., 2001. The landfill directive and the challenge ahead: demands and pressures on the UK householder. *Resour. Conserv. Recy.* 32, 333-348.
- Pomberger, R., Sarc, R., Lorber, K.E., 2017. Dynamic visualisation of municipal waste management performance in the EU using Ternary Diagram method. *Waste Manage.* 61, 558-571.
- Rigamonti, L., Grosso, M., Giugliano, M., 2009. Life cycle assessment for optimising the level of separated collection in integrated MSW management systems. *Waste Manage.* 29, 934-944.
- Rotter, V.S., Kost, T., Winkler, J., Bilitewski, B., 2004. Material flow analysis of RDF-production processes. *Waste Manage.* 24, 1005-1021.
- Ryu, C., Sharifi, V.N., Swithenbank, J., 2007. Thermal waste treatment for sustainable energy. *Proceedings of the Institution of Civil Engineers-Engineering Sustainability*, Thomas Telford Ltd, 133-140.
- Scharff, H., 2014. Landfill reduction experience in the Netherlands. *Waste Manage.* 34, 2218-2224.
- Sharholy, M., Ahmad, K., Vaishya, R.C., Gupta, R.D., 2007. Municipal solid waste characteristics and management in Allahabad, India. *Waste Manage.* 27, 490-496.
- Shekdar, A.V., 2009. Sustainable solid waste management: an integrated approach for Asian countries. *Waste Manage.* 29, 1438-1448.
- Shen, L.Y., Ochoa, J.J., Shah, M.N., & Zhang, X., 2011. The application of urban sustainability indicators—A comparison between various practices. *Habitat Int.* 35, 17-29.

- Shmelev, S.E., Powell, J.R., 2006. Ecological–economic modelling for strategic regional waste management systems. *Ecol. Econ.* 59, 115-130.
- Stanic-Maruna, I., Fellner, J., 2012. Solid waste management in Croatia in response to the European Landfill Directive. *Waste Manag. Res.* 30, 825-838.
- Sustainability Exchange (SE), 2000. National Waste Strategy 2000 for England and Wales.  
[http://www.sustainabilityexchange.ac.uk/key\\_elements\\_of\\_waste\\_strategy\\_2000\\_england\\_and\\_wales](http://www.sustainabilityexchange.ac.uk/key_elements_of_waste_strategy_2000_england_and_wales) (accessed 28 November 2016).
- Tai, J., Zhang, W., Che, Y., Feng, D., 2011. Municipal solid waste source-separated collection in China: A comparative analysis. *Waste Manage.* 31, 1673-1682.
- Tang, Y.T., Huang, C., 2017. Disposal of Urban Wastes. In: ABRAHAM, M. A. (ed.) *Encyclopedia of Sustainable Technologies*. Oxford: Elsevier. 365-377
- Taşeli, B.K., 2007. The impact of the European Landfill Directive on waste management strategy and current legislation in Turkey's Specially Protected Areas. *Resour. Conserv. Recycl.* 52, 119-135.
- Teixeira, C.A., Avelino, C., Ferreira, F., Bentes, I., 2014. Statistical analysis in MSW collection performance assessment. *Waste Manage.* 34, 1584-1594.
- Tsai, W.T., Chou, Y. H., 2006. An overview of renewable energy utilization from municipal solid waste (MSW) incineration in Taiwan. *Renew. Sust. Energ. Rev.* 10, 491-502.
- Tucker, P., Murney, G., Lamont, J., 1998. Predicting recycling scheme performance: a process simulation approach. *J. Environ. Manage.* 53, 31-48.
- Turner, D.A., Williams, I.D., Kemp, S., 2016. Combined material flow analysis and life cycle assessment as a support tool for solid waste management decision making. *J. Clean. Prod.* 129, 234-248.
- Uyarra, E., Gee, S., 2013. Transforming urban waste into sustainable material and energy usage: the case of Greater Manchester (UK). *J. Clean. Prod.* 50, 101-110.
- Vehlow, J., Bergfeldt, B., Visser, R., Wilén, C., 2007. European Union waste management strategy and the importance of biogenic waste. *J. Mater. Cycles Waste Manag.* 9, 130-139.
- Wang, D., He, J., Tang, Y.-T. & Higgitt, D. 2018. The EU Landfill Directive Drove the Transition of Sustainable Municipal Solid Waste Management in Nottingham City, UK. *Proceedings of the 7<sup>th</sup> Symposium on Energy from Biomass and Waste*. Venice, Oct 15–18 2018. CISA Publisher.
- Wang, Y. 2010. Fiber and textile waste utilization. *Waste Biomass Valori.* 1, 135-143.
- Wen, L., Lin, C.H., Lee, S.C., 2009. Review of recycling performance indicators: a study on collection rate in Taiwan. *Waste Manage.* 29, 2248-2256.

- Wicher, A., 2016. Fast fashion is creating an environmental crisis. <https://www.newsweek.com/2016/09/09/old-clothes-fashion-waste-crisis-494824.html> (accessed 4 September 2018).
- Wilson, D.C., Rodic, L., Scheinberg, A., Velis, C.A., Alabaster, G., 2012. Comparative analysis of solid waste management in 20 cities. *Waste Manage. Res.* 30, 237-254.
- Woolridge, A.C., Ward, G.D., Phillips, P.S., Collins, M., Gandy, S., 2006. Life cycle assessment for reuse/recycling of donated waste textiles compared to use of virgin material: An UK energy saving perspective. *Resour. Conserv. Recy.* 46, 94-103.
- World Energy Council, 2016. World Energy Resources Waste to Energy. [https://www.worldenergy.org/wp-content/uploads/2017/03/WEResources\\_Waste\\_to\\_Energy\\_2016.pdf](https://www.worldenergy.org/wp-content/uploads/2017/03/WEResources_Waste_to_Energy_2016.pdf) (accessed 30 December 2018).
- WRAP. 2018a. Our History. <http://www.wrap.org.uk/about-us/our-history> (accessed 4 September 2018).
- WRAP. 2018b. What We Do. <http://www.wrap.org.uk/about-us/what-we-do> (accessed 4 September 2018).
- Zaccariello, L., Cremiato, R., Mastellone, M.L., 2015. Evaluation of municipal solid waste management performance by material flow analysis: Theoretical approach and case study. *Waste Manage. Res.* 33, 871-885.
- Závodská, A., Benešová, L., Smyth, B., Morrissey, A.J., 2014. A comparison of biodegradable municipal waste (BMW) management strategies in Ireland and the Czech Republic and the lessons learned. *Resour. Conserv. Recy.* 92, 136-144.
- Zhang, D.Q., Tan, S.K., Gersberg, R.M., 2010. Municipal solid waste management in China: Status, problems and challenges. *J. Environ. Manage.* 91, 1623-1633.
- Zhuang, Y., Wu, S.W., Wang, Y.L., Wu, W.X., Chen, Y.X., 2008. Source separation of household waste: a case study in China. *Waste Manage.* 28, 2022-2030.
- Zorpas, A.A., Lasaridi, K., Abeliotis, C., Voukkali, I., Loizia, P., Georgiou, A., Chroni, C., Phanou, K., Bikaki, N., 2014. Waste prevention campaign regarding the Waste Framework Directive. *Fresenius Environ. Bull.* 23(11a), 2876-2883.

Table 1. The composition of MSW

Composition category	2006	2013
Paper & card	22.7%	14.4%
Food	17.8%	21.3%
Garden waste	15.8%	14.9%
Plastics	10.0%	8.6%
Glass	6.6%	5.5%
Metals	4.3%	3.7%
Wood	3.7%	2.7%
Textiles	2.8%	5.8%
WEEE	2.2%	2.8%
Other	14.0%	20.3%

WEEE: Waste electrical and electronic equipment.

Table 2. List of indicators selected

Description	Acronym	Definition	Application	Reference
Waste generation per capita	GPC	The MSW generated by each resident in a specific place (in this case is Nottingham) in a statistical year.	GPC is the quotient of the total MSW generation divided by the total population in an area. When the collection coverage is 100%, the total amount of waste generated equals the total amount of waste collected.	Makarichi et al. (2018)
Recycling rate	RCR	The ratio between the amount of waste prepared for recycling or the waste sent to producing secondary material and the total amount of waste generated.	It counts all material prepared for recycling from all sources including materials separated at source, at material recovery plant, and waste treatment and disposal plant, i.e. metal recovery from bottom ash at incineration plant.	(Haupt et al., 2017).
Separate delivery rate	SDR	The ratio between the amount of waste collected as separated streams and the total amount of waste generated.	It counts all separately collected recyclables and green waste, either alone or co-mingled. This indicator only takes the separately collected waste streams into account, without considering the quantity or percentage of waste actually addressed to recycling and recovery.	(Zaccariello et al., 2015)

---

Recovery rate	RECR	The ratio between the amounts of waste used for recovery options and the total amount of waste generated.	It counts waste sent to all types of treatment where energy is recovered, such as incineration with energy recovery and biogas production. Composting is usually not counted because no energy has been recovered, but landfill should be counted when landfill gas is recovered.	(Zaccariello et al., 2015)
Landfill rate	LCR	The ratio between the amount of waste disposed in landfill and the total amount of waste generated.	It counts all waste sent to landfill including the rejected and residual waste from waste treatment facilities, such as the rejected waste from composting plant, bottom ash and fly ash from incineration plant.	(Zaccariello et al., 2015)

---

Note: The sum of RCR, RECR and LCR is normally equal to or greater than 100% because the waste formulating bottom ash and fly ash counted twice by RECR and LCR.

In calculation, the total amount of waste generated equals the total amount of waste collected when the collection coverage is 100%.

Table 3. Results of the performance assessment of MSW management system for total MSW and selected classes of wastes

	Waste category	Metal	Garden	Plastics	Paper &	Textile	Glass	Wood	MSW
S1	Generated amount (t)	9,889	N/A	13,598	39,557	2472	11,125	N/A	123,615
	Percentage (%)	8.0	N/A	11.0	32.0	2.0	9.0	N/A	100.0
	GPC (kg/y)	37.0	N/A	50.9	148.2	9.3	41.7	N/A	463.0
	RCR (%)	N/A	N/A	N/A	N/A	N/A	N/A	N/A	3.4 (4.6)
	RECR (%)	N/A	N/A	N/A	N/A	N/A	N/A	N/A	40.7
	LCR (%)	N/A	N/A	N/A	N/A	N/A	N/A	N/A	54.7
S2	Generated amount (t)	5,582	20,523	12,968	29,454	3,674	8,620	4,842	129,814
	Percentage (%)	4.3	15.8	10.0	22.7	2.8	6.6	3.7	100.0
	GPC (kg/y)	20.0	73.6	46.5	105.7	13.2	30.9	17.4	465.8
	Recycled amount (t)	3,599	11,171	496	9,571	193	2,672	1,935	22,831
	RCR (%)	64.5	54.4	3.8	32.5	5.3	31.0	40.0	17.6 (26.2)
	Recovered amount (t)	0	477	11,814	15,261	2,413	0	191	73,333
	RECR (%)	0	2.3	91.1	51.8	65.7	0	3.9	56.5
	Disposed amount (t)	1,983	8,875	658	4,622	1,068	5,948	2,716	45,786
LCR (%)	35.5	43.2	5.1	15.7	29.1	69.0	56.1	35.3	
S3	Generated amount (t)	4,312	16,212	10,708	16,582	7,161	6,115	4,294	115,170
	Percentage (%)	3.7	14.1	9.3	14.4	6.2	5.3	3.7	100.0
	GPC (kg/y)	13.5	50.8	33.6	52.0	22.5	19.2	13.5	361.2
	Recycled amount (t)	2,681	14,899	1,880	7,881	95	3,625	4,110	36,760
	RCR (%)	62.2	91.9	17.6	47.5	1.3	59.3	95.7	31.9(44.9)
	Recovered amount (t)	0	1122	8623	7808	6940	0	92	71,267
	RECR (%)	0	6.9	80.5	47.1	96.9	0	2.2	61.9
	Disposed amount (t)	1,631	191	205	893	127	2,490	92	8,422
LCR (%)	37.8	1.2	1.9	5.4	1.8	40.7	2.1	7.3	

S4	Generated amount (t)	4,312	41,070*	10,708	16,582	7,161	6,115	4,294	115,170
	Percentage (%)	3.7	35.7*	9.3	14.4	6.2	5.3	3.7	100.0
	GPC (kg/y)	13.5	128.8*	33.6	52.0	22.5	19.2	13.5	361.2
	Recycled amount (t)	3,149	35,079*	3,900	11,768	1,050	4,967	4,110	38,847
	RCR (%)	73.0	85.4*	36.4	71.0	14.7	81.2	95.7	33.7 (63.7)
	Recovered amount (t)	0	13,007*	6,808	4,814	6,111	0	184	51,594
	RECR (%)	0	31.7*	63.6	29.0	85.3	0	4.3	44.8
	Disposed amount (t)	1,163	0*	0	0	0	1,148	0	4,093
	LCR (%)	27.0	0*	0	0	0	18.8	0	3.6

Note: values in brackets () represent the quantity and percentage of recycled waste plus the composted green garden waste. \*: The sum of food waste and garden waste in S4. GPC: waste generation per capita, RCR: Recycling rate, RECR: Recovery rate, LCR: landfill

rate.



Fig. 1. Timeline for national and local strategies, policies and actions for waste management responding to EU directives.

Fig. 2. Material flow analysis of situation 2. Dash lines are used to distinguish the pathways of material flow. The square in bold represents the boundary of inventory.

Fig. 3. Material flow analysis of situation 3. Dash lines are used to distinguish the pathways of material flow. The square in bold represents the boundary of inventory.

Fig. 4. MSW generation during 2001/02 – 2016/17 in Nottingham (Adapted from Wang *et al.* 2018 with additional data).

Fig. 5. Material flow analysis of the future scenario. Dash lines are used to distinguish the pathways of material flow. The square in bold represents the boundary of inventory.

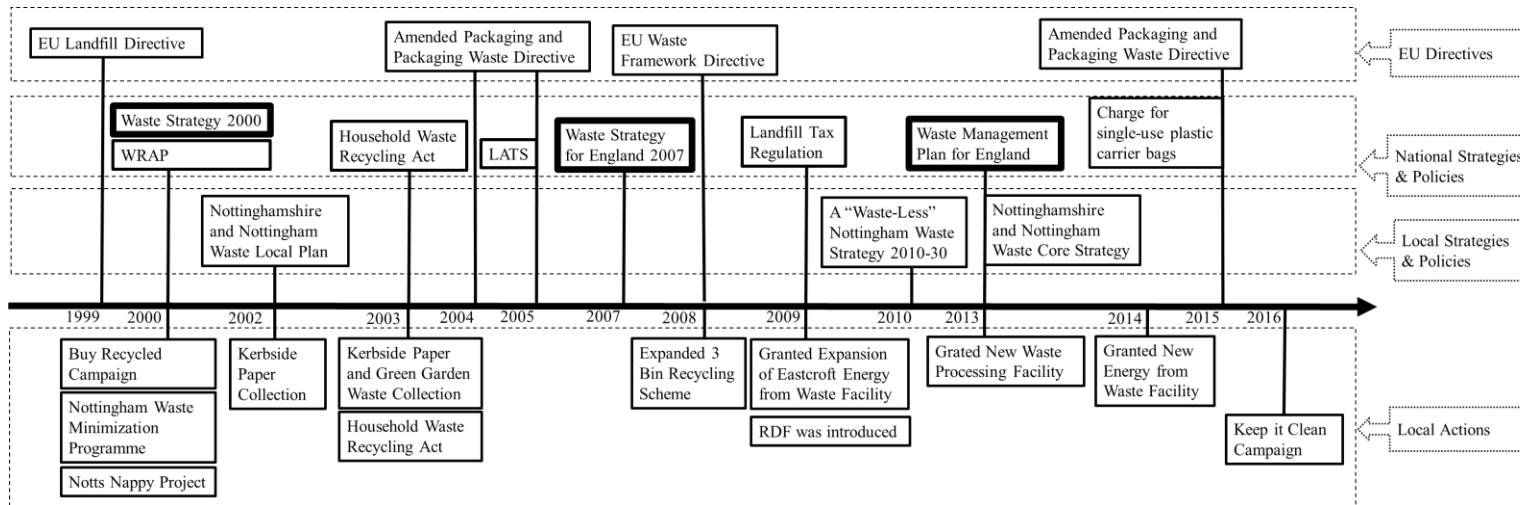

Fig. 1

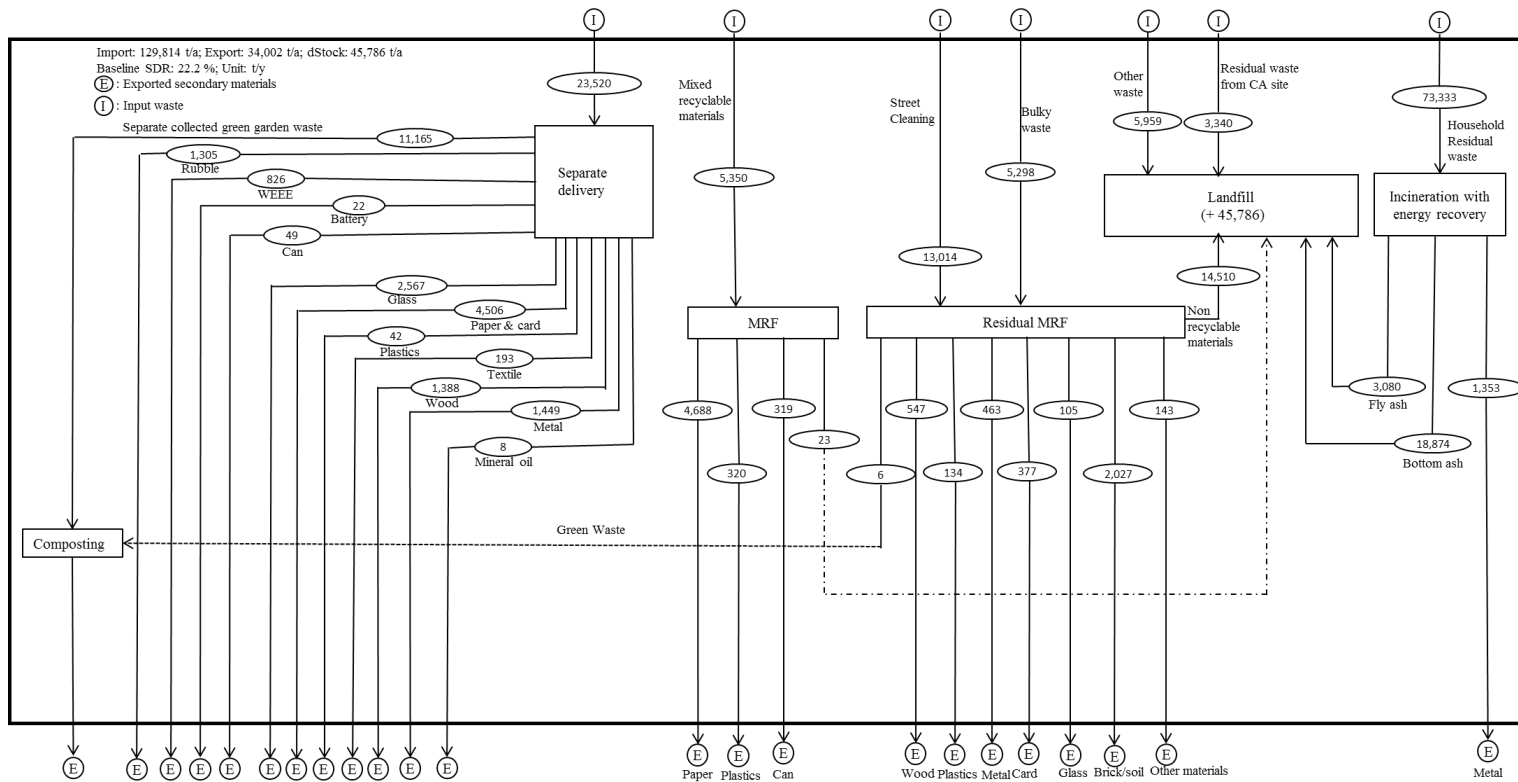

Fig. 2.

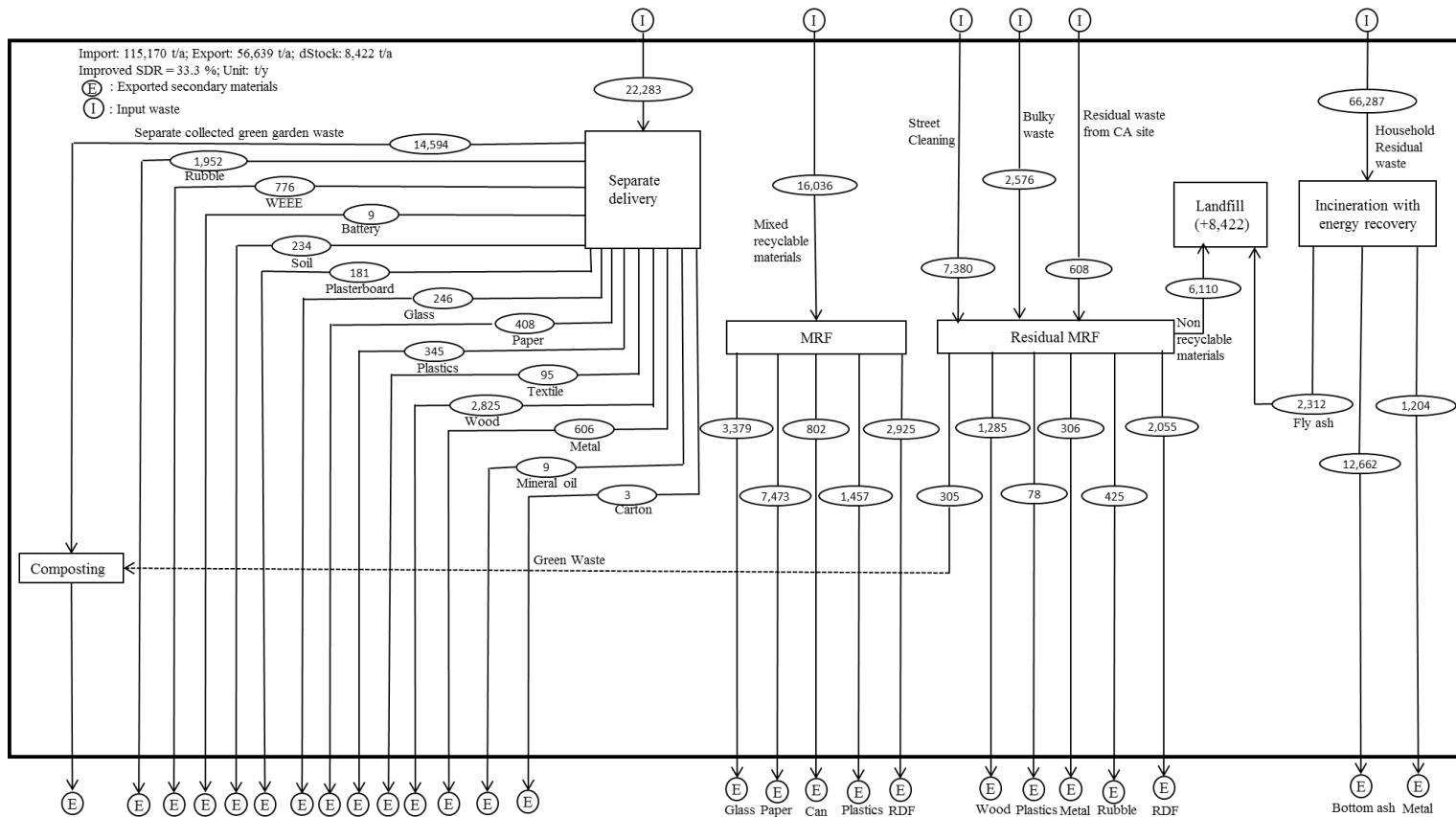

Fig. 3.

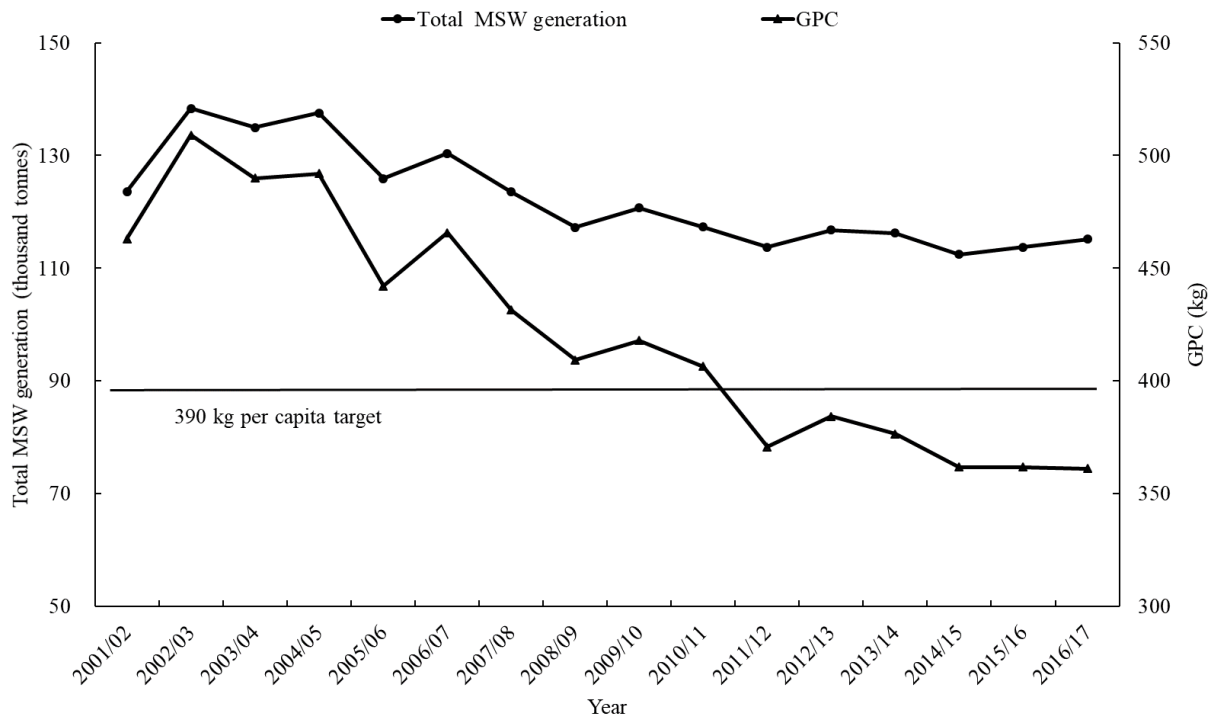

Fig. 4.

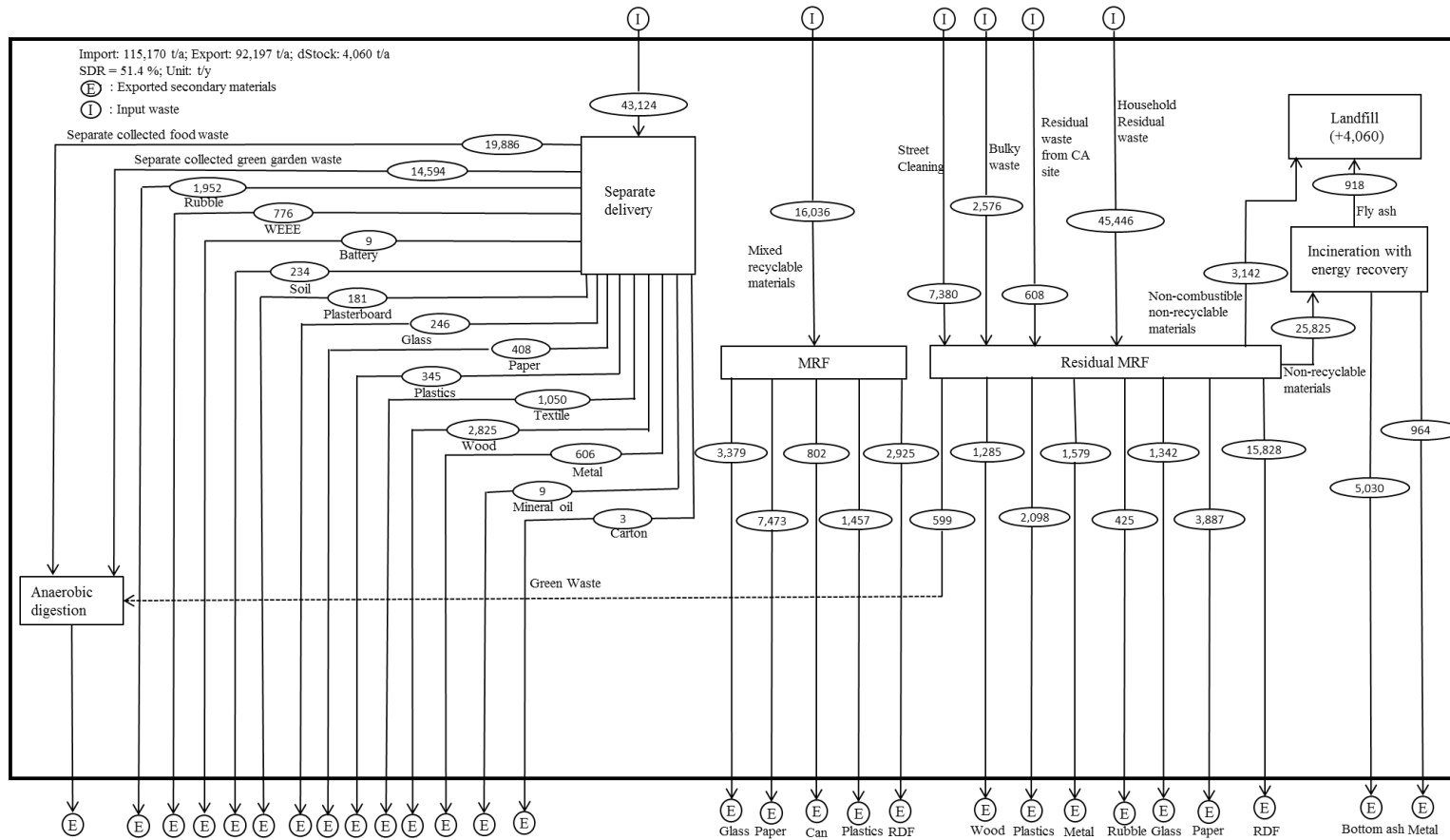

Fig. 5.